



Jarrahdale
Heating



Australia's Natural Choice in Home Heating

- ✓ Premium, Slow-combustion Wood Heaters
- ✓ Heavy duty, all solid-steel construction
- ✓ Advanced-burn technology for excellent heat output and lower emissions
- ✓ Australian made and owned since 1981
- ✓ Comprehensive warranty including 10-year Firebox Guarantee
- ✓ Built to comply with Australian Standards

Wood Heater Collection

FREESTANDING & FIREPLACE DESIGNS



Radiant Wood Heaters

Radiant Wood Heaters are great for traditional homes with several distinct rooms. They are also ideal for draughty rooms with less insulation as they efficiently heat the immediate living space.

Radiant Wood Heaters work by releasing infrared heat directly from the outer surface onto surrounding objects. This results in rapid, direct heat emission with more warmth retained in the lower portion of the room where it is needed. Optional side heat shields are available with all our Radiant Heaters.

SWAGMAN



Dimensions (mm): PEDESTAL 540 W x 710 H x 455 D
 ON LEGS 540 W x 685 H x 455 D
Heating Area: Up to 148sq/m*
Firebox Capacity: Logs up to 450mm W
Weight: 75kg
Option: Side heat shields for installation closer to combustible surfaces

The Swagman has been designed with modern, smaller homes in mind. As our most compact wood heater, it is perfect for saving space while efficiently heating up to 148sq/m, or approximately a three-bedroom home. Available with our standard pedestal base or with optional steel legs.

PIONEER



Dimensions (mm): PEDESTAL 630 W x 785 H x 530 D
 ON LEGS 630 W x 760 H x 530 D
Heating Area: Up to 232sq/m*
Firebox Capacity: Logs up to 580mm W
Weight: 104kg
Option: Side heat shields for installation closer to combustible surfaces

The Pioneer features a contemporary, square fascia with a wide viewing area. Our standard model features a modern, 320mm high pedestal base, allowing the firebox to sit at the perfect height for views of the flames. Also available with optional steel legs.

Convection Wood Heaters

Convection wood heaters are ideal for well-insulated and open-plan homes. Convection heaters create a cosy ambience by circulating warm air around the living space. As warm air rises it is displaced by cooler air, which then warms from the stove and rises to follow. This cycle creates a flow, with the hottest air pushing up to the ceiling and the warm air remaining in the lower part of the room to provide well-distributed, even warmth to your entire living area.

WOOD STACKER RANGE

NEW!

CONVECTOR WOOD STACKER



Dimensions (mm): 715 W x 1000 H x 520 D
Heating Area: Up to 232 sq/m*
Firebox Capacity: Logs up to 580mm W
Weight: 150kg
Features: Wood Storage Box
 Two-speed Fan

COUNTRYMAN WOOD STACKER



Dimensions (mm): 815 W x 1050 H x 520 D
Heating Area: Up to 300 sq/m*
Firebox Capacity: Logs up to 630mm W
Weight: 250kg
Features: Wood Storage Box
 Two-speed Fan

CLYDESDALE WOOD STACKER



Dimensions (mm): 915 W x 1050 H x 520 D
Heating Area: Up to 350 sq/m*
Firebox Capacity: Logs up to 730mm W
Weight: 290kg
Features: Wood Storage Box
 Two-speed Fan

The new Wood Stacker Range combines our most popular medium and large convection wood heaters, with built-in storage for firewood. Similar by name and design, each model offers the contemporary styling and features of its freestanding counterpart, with the addition of convenient access to timbers stored directly under the firebox. Keep your entire home cosy and warm while also maximising floor area with these space-saving designs.

The Wood Stacker Range is available in three different sizes to suit the scale and layout of your home, from medium-sized, through to large, open plan residences. All models feature side-heat shields for added protection and a two-speed fan to efficiently push warm air throughout the home.

RHAPSODY



Dimensions (mm): 610 W x 695 H x 530 D
Heating Area: Up to 185sq/m*
Firebox Capacity: Logs up to 450mm W
Weight: 129kg
Optional: Two-speed Fan

The Rhapsody is a compact wood heater ideal for small to medium residences, ranging up to a large three bedroom, or small four-bedroom home. Available with an optional two-speed fan to help circulate heat more efficiently.

INNOVATOR



Dimensions (mm): 730 W x 695 H x 530 D
Heating Area: Up to 232sq/m*
Firebox Capacity: Logs up to 580mm W
Weight: 152kg
Features: Grand style with wide glass door
Optional: Two-speed Fan

Recipient of an Australian Design Award for its striking appearance, the Innovator features a wide firebox and large glass door. The perfect heater for a medium-sized family home.

JUMBO INNOVATOR



Dimensions (mm): 730 W x 695 H x 650 D
Heating Area: Up to 280sq/m*
Firebox Capacity: Logs up to 580mm W
Weight: 175kg
Features: Deep firebox to load more logs
Optional: Two-speed Fan

The Jumbo Innovator is designed to warm spacious, open-plan living areas and homes with several rooms. It features a deep firebox to accommodate a greater volume of logs for longer lasting warmth.

CONVECTOR



Dimensions (mm): 715 W x 805 H x 520 D
Heating Area: Up to 232sq/m*
Firebox Capacity: Logs up to 580mm W
Weight: 113kg
Features: Side heatshields
Optional: Two-speed Fan
 Steel legs

The Convector features side heat shields for added heat protection and is available with the standard pedestal base or custom-made steel legs.

COUNTRYMAN



Dimensions (mm): 815 W x 865 H x 520 D
Heating Area: 300sq/m
Firebox Capacity: Logs up to 630mm W
Weight: 220kg
Features: Large glass door
 Two-speed fan

The Countryman boasts one of our largest fireboxes yet and is the perfect wood heater for a large residence, open-plan living areas and homes with high ceilings. It offers exceptional heat output, warming areas up to 300 sq/m.

CLYDESDALE



Dimensions (mm): 915 W x 865 H x 520 D
Heating Area: 350 sq/m
Firebox Capacity: Logs up to 730mm W
Weight: 260kg
Features: Large glass door
 Two-speed fan

The Clydesdale is our biggest wood heater yet, unrivalled for burn time and heat output. Designed for large residences and open-plan living areas, this grand heater features a powerful two-speed fan to push warm air throughout the home.

Standard Inclusions

- 4m Flue Kit including;
 - 2 lengths of internal single flue
 - 2 lengths of external triple-skin flue
 - Cowl and ceiling plate
- Choice of four modern surface finishes

Optional Extras

- Decorative Flue Mesh
- Flue guard
- Floor Hearth
- Drop box
- Side heat shields*
- Heritage-style steel legs*



FIREPLACE RANGE

RHAPSODY BUILT-IN



Firebox Size (mm): 590 W x 600 H x 330 D
Fascia Sizes (mm): 790 W x 710 H or 990 W x 810 H
Heating Area: Up to 185sq/m*
Firebox Capacity: Logs up to 450mm W
Weight: 129kg
Features: Two-speed Fan

The Rhapsody Built-in offers evenly distributed warmth to small and medium homes, such as a large 3 bedroom house. Available in a choice of two fascia sizes, you can select the size that best suits the scale of your fireplace area and home.

INNOVATOR BUILT-IN



Firebox Size (mm): 715 W x 600 H x 330 D
Fascia Sizes (mm): 920 W x 710 H or 1120 W x 810 H
Heating Area: Up to 232sq/m*
Firebox Capacity: Logs up to 580mm W
Weight: 152kg
Features: Two-speed Fan

The Innovator Built-In features a two-speed fan for even heat distribution and is available in a choice of two fascia sizes, so you can select the size that best suits the scale of your fireplace area and home. The ideal wood heater for a medium-sized home.

JUMBO INNOVATOR BUILT-IN



Firebox Size (mm): 715 W x 600 H x 450 D
Fascia Sizes (mm): 920 W x 710 H or 1120 W x 810 H
Heating Area: Up to 280sq/m*
Firebox Capacity: Logs up to 580mm W
Weight: 175kg
Features: Two-speed Fan

The Jumbo Built-in offers excellent heating in large, open plan areas or homes with several rooms. It features a two-speed fan for even heat distribution and a large, rectangular firebox and glass door panel. Available in two fascia sizes.

CONVECTOR BUILT-IN



Firebox Size (mm): 650 W x 600 H x 450 D
Fascia Size (mm): 975 W x 750 H
Heating Area: Up to 232sq/m*
Firebox Capacity: Logs up to 450mm W
Weight: 113kg
Features: Two-speed Fan

The Convactor Built-In offers a sleek and minimalistic appearance to suit contemporary homes. Its design includes a one-piece, linear fascia, and discreet flush fittings. Features include a large door opening and over-sized firebox to heat up to 232sq/m.

COUNTRYMAN BUILT-IN



Firebox Size (mm): 750 W x 650 H x 450 D
Facia Size (mm): 930 W x 800 H
Heating Area: Up to 300 sq/m*
Firebox Capacity: Logs up to 530mm W
Weight: 220kg
Features: Two-speed Fan

An impressive fireplace offering extended burn time and superior heat output, warming up to 300 sq/m. The perfect wood heater for a large residence, open-plan living area and homes with high ceilings.

CLYDESDALE BUILT-IN



Firebox Size (mm): 850 W x 650 H x 450 D
Facia Size (mm): 1030 W x 800 H
Heating Area: Up to 350 sq/m*
Firebox Capacity: Logs up to 630mm W
Weight: 250kg
Features: Two-speed Fan

The Clydesdale Built-In is our largest fireplace wood heater, unrivalled for burn time and heat output. Designed to bring long-lasting, permeating warmth to large residences and expansive, open-plan living areas.

Customise your Fireplace Heater

Every built-in wood heater from Jarrahdale Heating is locally manufactured and made-to-order. This allows us to offer a range of customisations to suit your home and ensure the very best fit.

COMMON CUSTOMISATIONS INCLUDE:

Flue Placement

Move the standard flue centre backward, to line-up with your existing chimney centre.

Fan Power Cord

Position the power cord to suit the location and distance of the closest power point. The fan power cord can protrude from the left or the right side of the heater and can be extended to avoid the use of extension cords.

Fascia Size

If the standard fascia sizes are not ideal for your existing fireplace opening, we can manufacture a custom-fascia to fit.

Custom Chimney Covers

All chimneys are different and sometimes the standard chimney cover is too small. We can manufacture the correct chimney cover to suit your home.



SURFACE FINISHES

Jarrahdale Wood Heaters are available in a range of four attractive surface finishes. Every heater is heat-painted onsite at our manufacturing facility using Stove Bright® high temperature paint. This ensures your heater maintains its brilliant colour, even in excessive heat.

METALLIC
BLACK



METALLIC
BLUE



GOLDFIRE
BROWN



TITANIUM



*Due to differences in printing processes the colours shown may vary from the physical product and should only be used as a general guide. To see the exact colour, please request a colour sample.

Standard Installation Requirements



FREESTANDING WOOD HEATERS

The following diagrams illustrate the minimum clearances required for installation of Jarrahdale freestanding wood heaters next to combustible walls and on combustible flooring.

When wall materials are combustible, such as timber, a half-round Safety Flue Guard with a minimum height of 1000mm is required for all freestanding models. Your wood heater may be installed closer than shown if wall materials are not considered combustible, such as brick or plaster, or if the wall is protected by an additional shield. Please consult your sales representative for further advice.

If the wood heater is installed onto combustible flooring such as carpet, vinyl or cork, a hearth is required with adequate front clearance, as shown below.

RHAPSODY, CONVECTOR, CONVECTOR WOOD STACKER, INNOVATOR & JUMBO

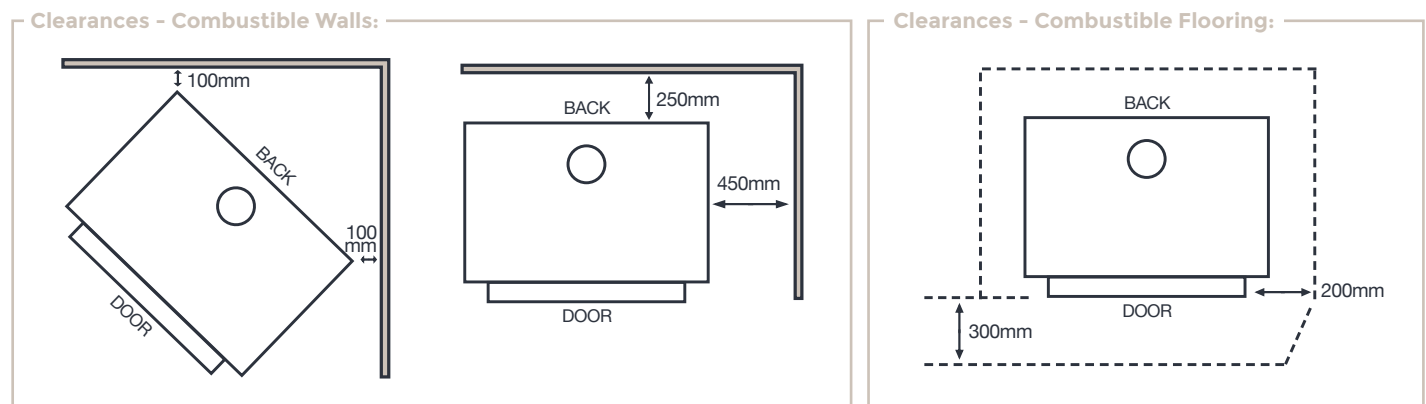

PIONEER & SWAGMAN (ON PEDESTAL OR LEGS)

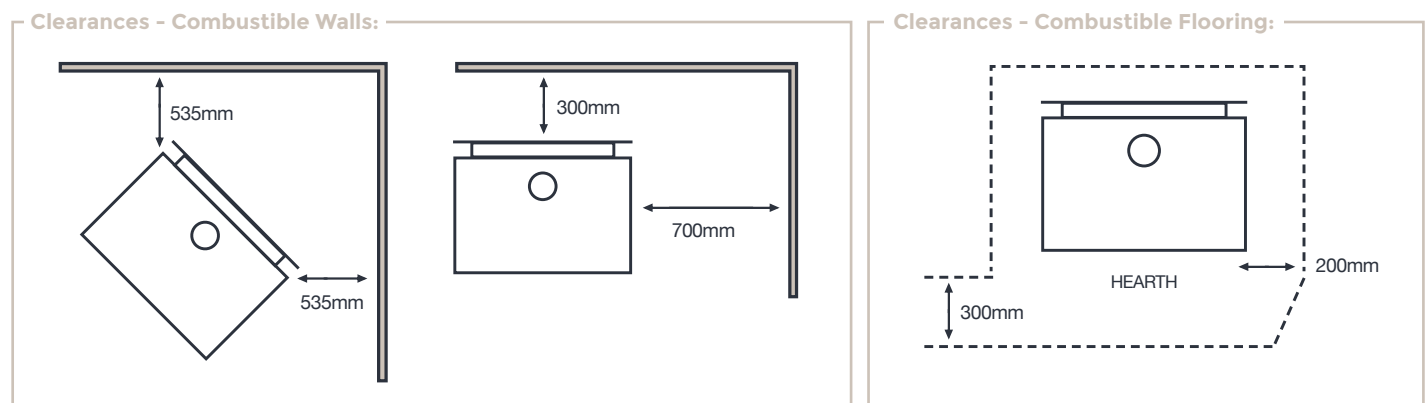

COUNTRYMAN & COUNTRYMAN WOODSTACKER

CLYDESDALE & CLYDESDALE WOODSTACKER

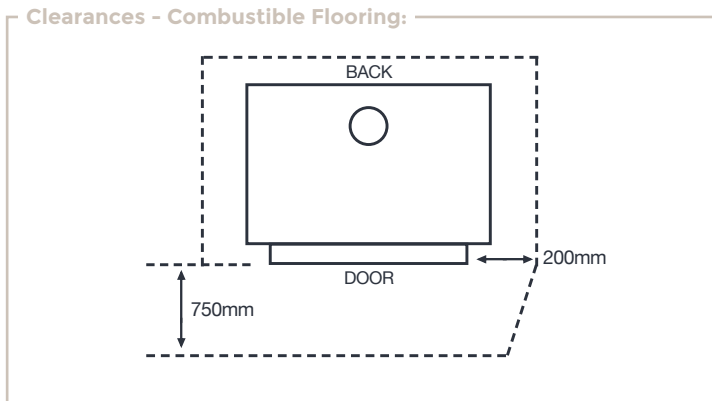
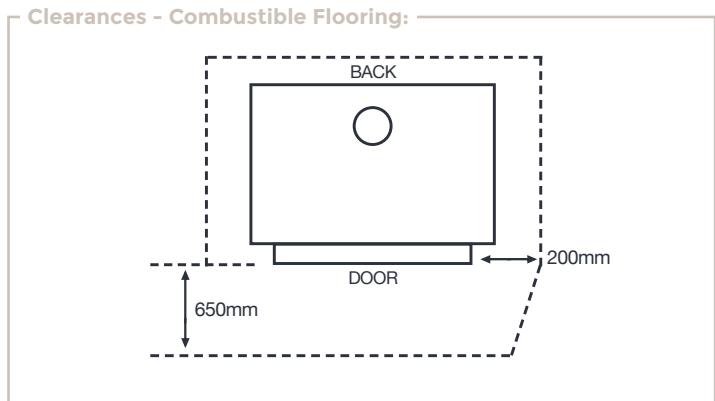
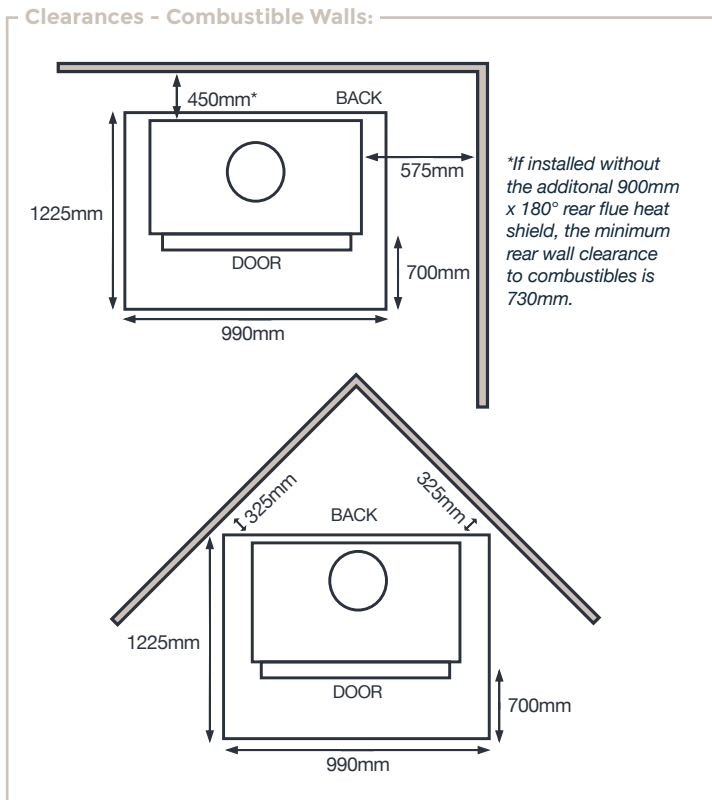
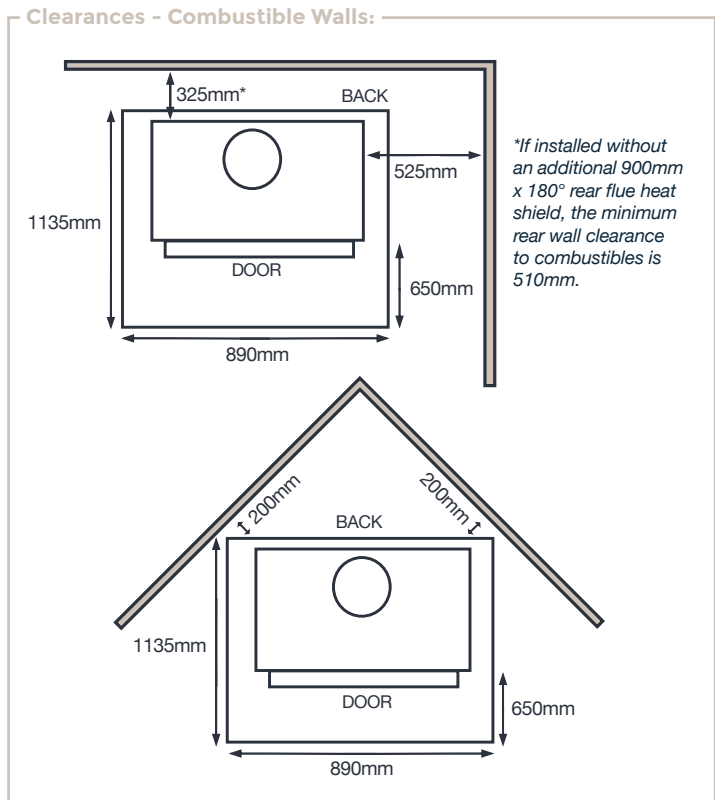

FLUE CENTRES

Flue centre measurements shown in the table below are measured from the back of the wood heater.

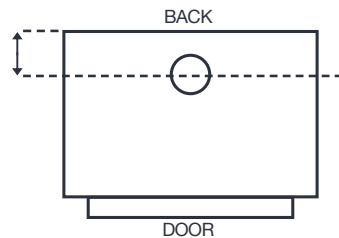

MODEL	RHAPSODY, CONVECTOR, CONVECTOR WOODSTACKER, INNOVATOR, COUNTRYMAN, & COUNTRYMAN WOODSTACKER	JUMBO INNOVATOR	CLYDESDALE	SWAGMAN	PIONEER
FLUE CENTRE	170mm	190mm	170mm	180mm	200mm
DIAMETER	150mm	150mm	195mm	150mm	150mm



FIREPLACE WOOD HEATERS

The following diagrams illustrate the minimum clearances required for installation of Jarrahdale built-in wood heaters into a masonry or non-combustible fireplace cavity. This includes minimum cavity dimensions and hearth requirements.

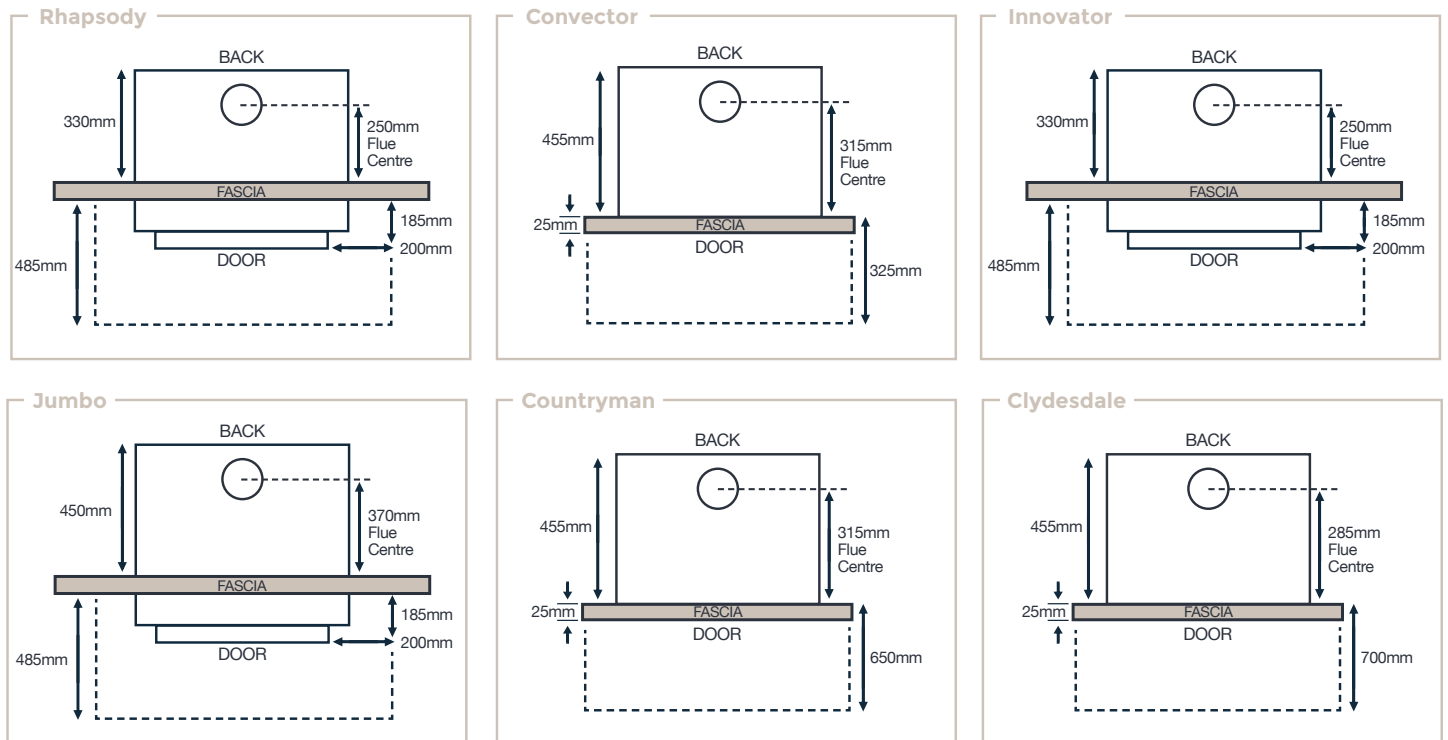



There is nothing quite like a roaring fire. Slow Combustion Wood Heaters leave your entire home warm and cosy and are cost efficient to run. That's why Jarrahdale Wood Heaters have been a leading choice in home heating since 1981.

Jarrahdale's complete range of premium wood heaters are manufactured at a purpose-built manufacturing facility in Maddington, Western Australia and comply with strict Australian Standards. Each heater is made from locally sourced, solid steel and is constructed using state-of-the-art plasma and laser cutting technologies. Jarrahdale Heating even weld, fit and heat-paint each wood heater to guarantee product quality, strength, and durability.

Jarrahdale Heating are proud members of the Australian Home Heating Association (AHHA), the peak industry governing body for the manufacture of wood heaters in Australia. As such, Jarrahdale work closely with the AHHA to ensure each wood heater is compliant with industry best practices. As a result, every Jarrahdale Wood Heater is backed by a competitive 10-year structural warranty; a seal of quality assurance.

AVAILABLE FACTORY-DIRECT & AUSTRALIA-WIDE THROUGH A CERTIFIED DISTRIBUTOR



SHOWROOM: 10 Malcolm Rd, Maddington WA
Phone: **08 9493 6512** | Online: **www.jhc.com.au**

*Jarrahdale Heating reserves the right to alter designs and specifications due to on-going product improvements.

Certified Dealer: